

X S S E R I E S

Pneumatici omologati CIK/FIA 2005-2007 di
mescola media
Homologation CIK/FIA 2005-2007 tyres of
medium compound



- 1
- 2
- 3
- 4
- 5
- 6
- 7
- 8
- 9



High Technology in Karting Tyres

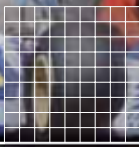

white label



VEGA

5"

→ omologazione CIK/FIA 2005-2007 → 2005/2007 CIK/FIA homologation → omologazione CIK/FIA 2005-2007

X S

S E R I E S

Pneumatici omologati CIK/FIA 2005-2007 di
mescola media

Homologation CIK/FIA 2005-2007 tyres of
medium compound



La VEGA ha stabilito che anche per gli anni 2005/2007 i pneumatici di omologazione CIK/FIA di mesola "media" saranno chiamati XS. Questo marchio è sinonimo di qualità costruttiva e, soprattutto, di performance. Fino ad oggi infatti, la XS è stata scelta dalla stragrande maggioranza dei piloti che partecipano a tutti i campionati continentali e nazionali, ove sia previsto l'utilizzo di pneumatici omologati a mescola media. In vista di questo nuovo periodo di omologazione, abbiamo ulteriormente perfezionato il pneumatico, per mantenere la leadership conquistata in passato. Il risultato ottenuto è un formidabile compromesso di grip e resistenza all'abrasione, con performance costanti per tutta la durata del battistrada.



- [1] **Alessandro Manetti**
1° Italian Open Master Championship 125 ICC - 2004
- [2] **Henk Waldschmidt**
1° Italian Open Master Championship 100 ICA - 2004
- [3] **Eng Philipp**
1° Italian Open Master Championship 100 ICA J - 2004



High Technology in Karting Tyres



rear
[XS 71]

front
[XS 46]

VEGA

Vega has decided that homologated medium compound tyres for the years 2005/2007 will still be named "XS". This brand name is synonymous with high quality manufacturing and, above all, synonymous with the ultimate racing performance. In fact until now, the "white" has been chosen by the majority of drivers in all European championships, where homologated medium compound tyres are required. In view of the new homologation period, we have further improved the tyre, with the clear goal to retain the market domination we have had during the past three years. The results we have achieved are the ultimate optimisation of the levels of grip and wear resistance, to produce a tyre with consistent performance for the entire life of the tread.

- 1
- 2
- 3
- 4
- 5
- 6
- 7
- 8
- 9



2.



3.

Dati tecnici

Technical Data

XS

CODICE / CODE	XS SERIES		
	XS46	XS65	XS71
Misura / Size	10x4.60-5	11x6.50-5	11x7.10-5
L mm ±5	133	178	208
B mm ±5	105	128	142
C mm ±3	120	168	198
d mm +0 -1	126,2	126,2	126,2
D mm ±6	259	274	273
Durezza IRHD ±3 Superficial thread hardness	38	36	36.5
Peso ±5% Weight ±5%	Kg. 1,110	1,470	1,630
Press. Sug. ±0.2 Sug. Press. ±3	BAR PSI 0,56 8	0,56 8	0,56 8
Velocità max Max Speed	Km/h Mp/h 200 125	200 125	200 125

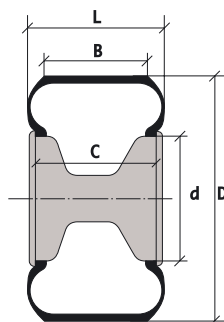

rear [XS 65]

front [XS 46]



High Technology in Karting Tyres

Per maggiori informazioni:
For more informations:

www.vegatyres.com

VEGA

Vega S.p.A.

Via Archimede, 10 · 21047 Saronno (VA) - Italy

Tel. (+39) 02.96451201 · Fax (+39) 02.96451192

vegadeal@vegatyres.com

XP S E R I E S

Pneumatici omologati CIK/FIA 2005-2007 di
mescola morbida
Homologation CIK/FIA 2005-2007 tyres of
soft compound



- 1
- 2
- 3
- 4
- 5
- 6
- 7
- 8
- 9



High Technology in Karting Tyres

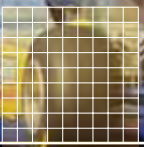

yellow label

XP



VEGA

5"

→ omologazione CIK/FIA 2005-2007 → 2005/2007 CIK/FIA homologation → omologazione CIK/FIA 2005-2007

XP S E R I E S

Pneumatici omologati CIK/FIA 2005-2007 di
mescola morbida
Homologation CIK/FIA 2005-2007 tyres of
soft compound



Pneumatici VEGA di nuova omologazione CIK/FIA per gli anni 2005/2007 di mescola "morbida".

XP è l'ulteriore evoluzione tecnologica della già vincente "gialla" XT, dominatrice della Coppa del Mondo nella categoria Super Ic-C 2004 con l'ottimo Ennio Gandolfi (Birel-TM) e 2003 con Robert Dircks (Birel-TM) .

Costruite con mescole e carcasse di massimo livello tecnologico, le nuove XP assicurano prestazioni uniche in termini di grip, scorrevolezza e facilità di guida.

Quest'ultimo aspetto, in particolare, è sempre stato motivo di esaltazione da parte dei piloti secondo i quali "le gialle sono i pneumatici più facili da guidare".



- [1] **Ennio Gandolfi**
1° World Cup 125 Super ICC - 2004
- [2] **Davide Foré**
1° Italian Open Master Championship 100 FA - 2004
- [3] **Francesco Laudato**
1° European Championship 125 Super ICC - 2004



High Technology in Karting Tyres



rear

front

VEGA

These are the new Vega soft compound tyres for the CIK/FIA homologation period 2005/2007.

The XP tyre is the latest evolution of the already successful "yellow label" XT, which has dominated the 2004 Super Ic-C World Cup thanks to the Italian driver Ennio Gandolfi (Birel-TM) and also the 2003 edition won by Robert Dircks (Birel-TM).

The structure and compound engineering are both at the cutting edge of tyre technology, so that the new XP tyre assures unique performance in the terms of grip, rolling resistance and finally an outstanding distinction, easiness of driving.

All the drivers say that "the yellow tyres are the easiest to drive!"



F. Laudato, E. Gandolfi, R. Toninelli

- 1
- 2
- 3
- 4
- 5
- 6
- 7
- 8
- 9



2.



3.

Dati tecnici

Technical Data

XP

Misura / Size	10x4.60-5	11x7.10-5
L mm ±5	133	208
B mm ±5	105	142
C mm ±3	120	198
d mm +0 -1	126,2	126,2
D mm ±6	259	273
Durezza Superficial thread hardness	IRHD ±3 35	35
Peso ±5% Weight ±5%	Kg. 1,135	1,620
Press. Sug. ±0.2 Sug. Press. ±3	BAR 0,56	PSI 8
Velocità max Max Speed	Km/h 125	Mp/h 125

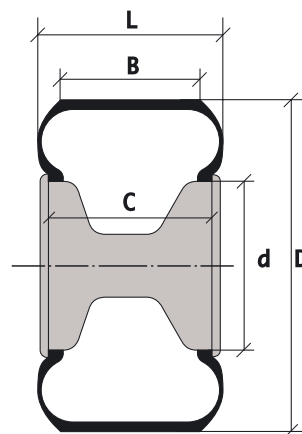

XP



High Technology in Karting Tyres

VEGA

Vega S.p.A.

Via Archimede, 10 · 21047 Saronno (VA) - Italy

Tel. (+39) 02.96451201 · Fax (+39) 02.96451192

vegadeal@vegatyres.com