

IAME

Parilla

125cc LEOPARD TaG engine

2003



**ASSEMBLY INSTRUCTIONS
and
USER MANUAL**

INDEX

	Page
GENERAL DESCRIPTION OF THE "LEOPARD" ENGINE	1
CHARACTERISTICS OF THE "LEOPARD" ENGINE – OPERATIONAL LIMITS	2
1- Contents of the packing	3
2- Motor identification Number	4
3- Preparation and installation of the engine on the chassis	5
3.1 Install the water cooling system	5
3.2 Exhaust header assembly	9
3.3 Preparation and installation of the motor-mount	9
3.4 Install the carburetor	10
3.5 Install the engine on the chassis	12
3.6 Install the clutch cover with H.T. coil	13
3.7 Installation and connection of the power pack box	14
3.8 Electrical connections on the engine	15
3.9 Installation of the intake silencer	18
3.10 Install the exhaust	19
4- GASOLINE and OIL	20
5- Carburetor Adjustment guide	21
6- Starting and stopping the engine	22
7- Engine break-in	22
8- Inlet silencer	22
9- Exhaust system	23
10- Centrifugal clutch	23
11- Instructions for the assembly/disassembly of the clutch	25
12- Battery	26
13- Spark plug and thermal degree	27
14- Choice of the best sprocket ratio	28
15- Scheduled maintenance	31
16- Troubleshooting	32
17- Engine and accessories preservation	33
Attachments: - Fastener Torque Table	34
- Wiring diagram	35

GENERAL DESCRIPTION OF THE "LEOPARD" ENGINE

This engine of the "TaG" series (Touch and Go) has been expressly designed and developed for the powering of karts for hobby racing on closed tracks, destined for this specific purpose. When designing this new line of engines, the technical solutions already adopted for the high performance engines were used, in order to guarantee the highest reliability of components, when the operating limitations are respected.

The motor is a single cylinder using the two stroke principle.

The cylinder and the crankcase are in aluminium alloy.

The pressed in liner is made of centrifugated cast iron, fully machined to guarantee the best possible stability.

The head is separated from the cylinder and secured by studs.

The crankshaft is built and supported by two ball-bearings. The crankshaft is of steel alloy, hardened and tempered, as is the connecting rod which runs on roller bearings.

The ignition includes a 4 pole stator/rotor with integral pick-up, an H.T. coil and an electronic unit with micro-processor (Power-Pack), complete with wiring harness.

The main features of the ignition are:

- During the start of the engine, the power-pack activates a booster which increases the spark energy to facilitate the starting of the engine.
- The ignition system permits, through the electronic unit, the onboard battery recharging during the normal use of the engine.
- The spark is generated also without a battery: it is therefore possible, in case of emergency, to start the engine with an external starter unit.

The engine has an integrated electric starter; by pushing the green start button the starter activates a bendix type gear which engages the starter ring assembled on the clutch.

The engine is provided with an automatic dry centrifugal clutch with low maintenance and with interchangeable sprocket.

The carburetor is a diaphragm Tillotson carburetor with integral fuel pump, filter and all position mounting capability.

The battery (12 V- 7.2Ah) is a sealed, no maintenance battery and is supplied already preassembled in the Power Pack support box which can be easily adapted to all existing chassis.

The exhaust, included in the supply, is already tuned for the best possible performance.

The engine is supplied with a kit which includes the radiator, the pump, water hoses and whatever necessary for the assembly on the kart.

CHARACTERISTICS OF THE "LEOPARD" ENGINE - OPERATIONAL LIMITS

1. The characteristics of the engine are the following :

- Cycle: OTTO / 2 stroke
- Original cubic capacity: 123.7 cc
- Original bore: 54.00 mm
- Max. theoretical bore: 54.28 mm
- Stroke: 54.00 mm
- Lubrication : Fuel-Oil mix
- Induction: Reed valve
- Carburetor: Membrane , Tillotson
- Cooling : water
- Ignition: Digital / 4 poles with internal rotor
- Battery charge: With integral generator
- Electric start: 12V/0.30 Kw
- Clutch: Automatic, dry, centrifugal

2. OPERATIONAL LIMITS:

- Max. RPM : 15000 RPM
- Min. waterTemperature: 45°c
- Max. water Temperature: 90°c



ATTENTION:

Never exceed the above limits, no obligation of IAME exists in case the above limits are exceeded.

1- CONTENT OF THE PACKING

Each Leopard engine is delivered with the under shown accessories:

	-125 cc LEOPARD- TaG engine
EXHAUST	
• Flexible	1
• Spring For Flexible	3
• Exhaust Fiber Strip	1
• Exhaust Header	1
• Exhaust Muffler	1
INDUCTION	
• Tillotson Carburetor	1
• Intake Silencer	1
• Intake Silencer Support	1
• Accelerator Cable Bracket	1
ELECTRICAL	
• Battery 12 V	1
• Battery Support	1
• Battery Strap	1
• Battery Clamps	2
• Power Pack Box with Harness	1
• Plastic Fixing Clamps	8
• NGK BR 10 EG Spark Plug	1
• Spark Plug Cap	1
MISCELLANEOUS	
• Additional Engine Plate	1
• Water proof cover	1
• Clutch cover with H.T. coil	1
WATER COOLING	
• Radiator	1
• Radiator Support Kit	1
• Complete Hose Kit	1
• Pump, complete	1

2- MOTOR IDENTIFICATION NUMBER

The official motor identification number can be found stamped in the lower left part of the crankcase, next to the electric starter (see fig.) The number normally includes a letter followed by 4 digits (there can be exceptions in some special cases). Other numbers stamped on the crankcase or other surfaces of the motor refer to various manufacturing processes and do not identify the motor.

NOTE:

In case of need for spares and when contacting the IAME Support Centers, please always refer to the Motor Identification Number and to the motor model.



3- PREPARATION AND INSTALLATION OF THE ENGINE ON THE CHASSIS

NOTE:

In case the engine is supplied already assembled on the chassis, it is at care of the assembler to follow these instructions. The final customer, in this case, can skip this section and can start reading from section 4.

Whenever the engine or a component is disassembled, it is necessary to always follow the under shown instructions for proper reassembly.

3.1- INSTALL THE WATER COOLING SYSTEM

NOTE:

To install the water pump belts it is necessary to remove the rear axle.

1	REINSTALL THE REAR AXLE AFTER HAVING INSERTED THE TWO BELTS. SUGGESTION: INSTALL OTHER TWO BELTS AS SPARES AND FIX THEM WITH TAPE TO THE AXLE.	
2	INSTALL THE WATER PUMP (1 SCREW M6 X 45 WITH WASHER AND SELF LOCKING NUT) ON THE PUMP BRACKET ON THE REAR CROSS RAIL (SEE FIG. 1). IN CASE THERE IS NO BRACKET FOR THIS PURPOSE IT IS NECESSARY TO INSTALL THE PUMP ON REMOVABLE CLAMPS AVAILABLE IN DIFFERENT DIAMETERS (Ø 28/30/32mm) AS ACCESSORIES (SEE FIG. 2). TIGHTEN BY HAND THE SCREW ON THE PUMP LETTING IT FREE TO ROTATE FOR THE TENSIONING OF THE BELTS.	 <p>Fig.1</p>  <p>Fig.2</p>
3	INSTALL ON THE AXLE THE DRIVING PULLEY (n°2 CLAMPS AVAILABLE IN DIFFERENT DIAMETERS Ø 30/35/40/50mm) ALIGNING ITS RACES WITH THE DRIVEN PULLEY. TIGHTEN THE CLAMPS WITH TWO SCREWS M6 X 25.	 <p>Fig.3</p>

4

INSTALL THE BELTS AND TENSION (SEE FIG. 4).



Fig.4

BEFORE INSTALLING THE RADIATOR PREASSEMBLE THE FOLLOWING COMPONENTS

5

INSERT THE RUBBER DAMPENERS INTO THE FIXING HOLES OF THE RADIATOR AND INSERT THE SPACERS (SEE FIG. 5).

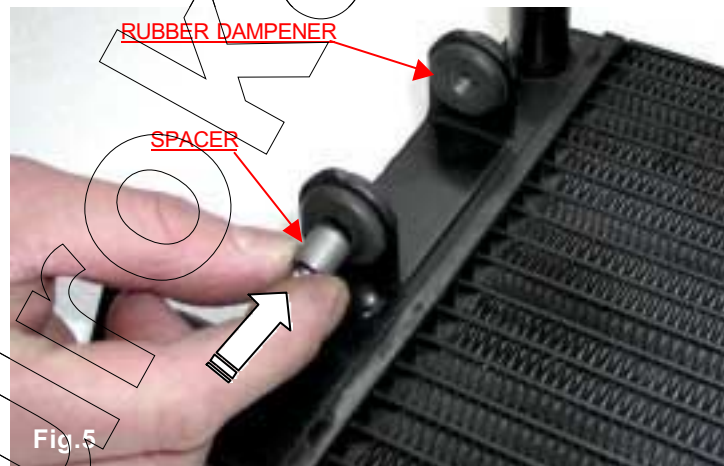

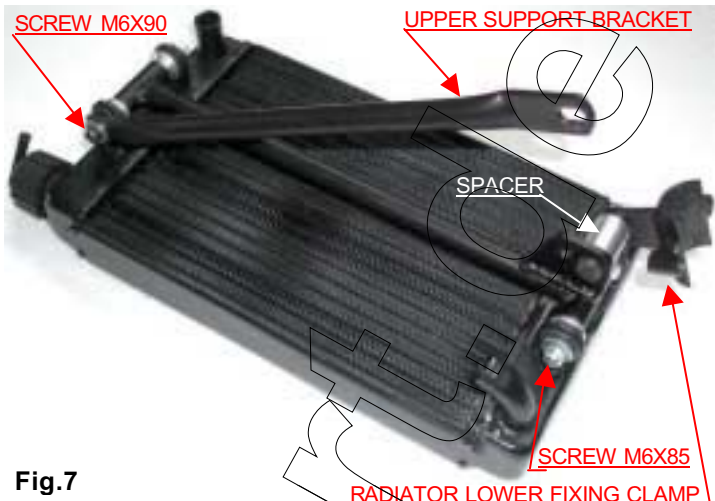

Fig.5

6

INSERT THE BUSHES INTO THE RADIATOR SUPPORT BRACKET. PLACE THE BRACKET BETWEEN THE RADIATOR FIXINGS (SEE FIG. 6).

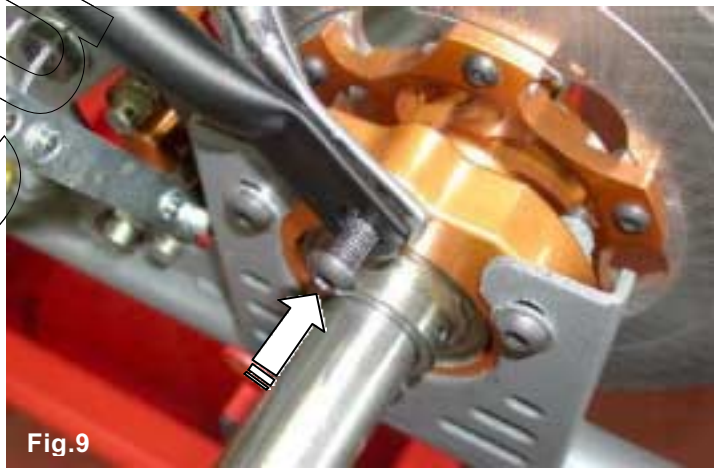

Fig.6

<p>7</p>	<p>FIX THE SUPPORT BRACKET TO THE RADIATOR, AND ALSO INSERT THE UPPER SUPPORT BRACKET (SCREWS M6X90 AND M6X85 WITH NUTS). PLACE THE RADIATOR LOWER FIXING CLAMP AND THE SPACER ON THE RADIATOR SUPPORT BRACKET (SCREW M8X45 WITH NUT) (SEE FIG. 7).</p>	 <p>Fig.7</p>
<p>8</p>	<p>PLACE THE LOWER FIXING CLAMP ON THE CHASSIS SIDE RAIL (BRAKE SIDE) (N°2 SCREWS M8X45 WITH NUTS) TIGHTEN THE BOLTS BY HAND (SEE FIG. 8).</p>	 <p>Fig.8</p>
<p>9</p>	<p>PLACE THE RADIATOR SO THAT THE HOLE, ON THE UPPER RADIATOR BRACKET, AND ONE OF THE UPPER HOLES ON THE BEARING SUPPORT BOX, MATCH (SEE FIG. 9). ONCE YOU FIND THE CORRECT POSITION, TIGHTEN ALL THE BOLTS</p>	 <p>Fig.9</p>
<p>10</p>	<p>THE KIT INCLUDES THREE RUBBER HOSES. CONNECT THE FIRST HOSE TO THE FITTING ON THE RADIATOR INLET AND THE FITTING ON THE ENGINE OUTLET, TIGHTEN WITH STEEL CLAMPS (SEE FIG.10).</p>	

11

CONNECT THE SECOND HOSE BETWEEN THE FITTINGS ON THE RADIATOR OUTLET AND THE PUMP INLET.
CONNECT THE THIRD HOSE BETWEEN THE FITTINGS ON THE PUMP OUTLET AND THE ENGINE INLET (SEE FIG. 10).
TIGHTEN WITH STEEL CLAMPS.



BEFORE STARTING THE ENGINE FOLLOW THESE RECOMMENDATIONS:

- Unscrew the cap on the radiator and loosen the breather plug on the engine head.
- Fill the radiator until the water comes out from the plug on the head (there is no air in the system now) and the radiator is completely filled. Tighten the cap (the system contains appr. 1 lt. of water).
- **It is advisable to put a small cup to recover water from the breather on the cap in case of boiling water.**
- **After the engine run-in, check the water level in the radiator and top up if necessary.**

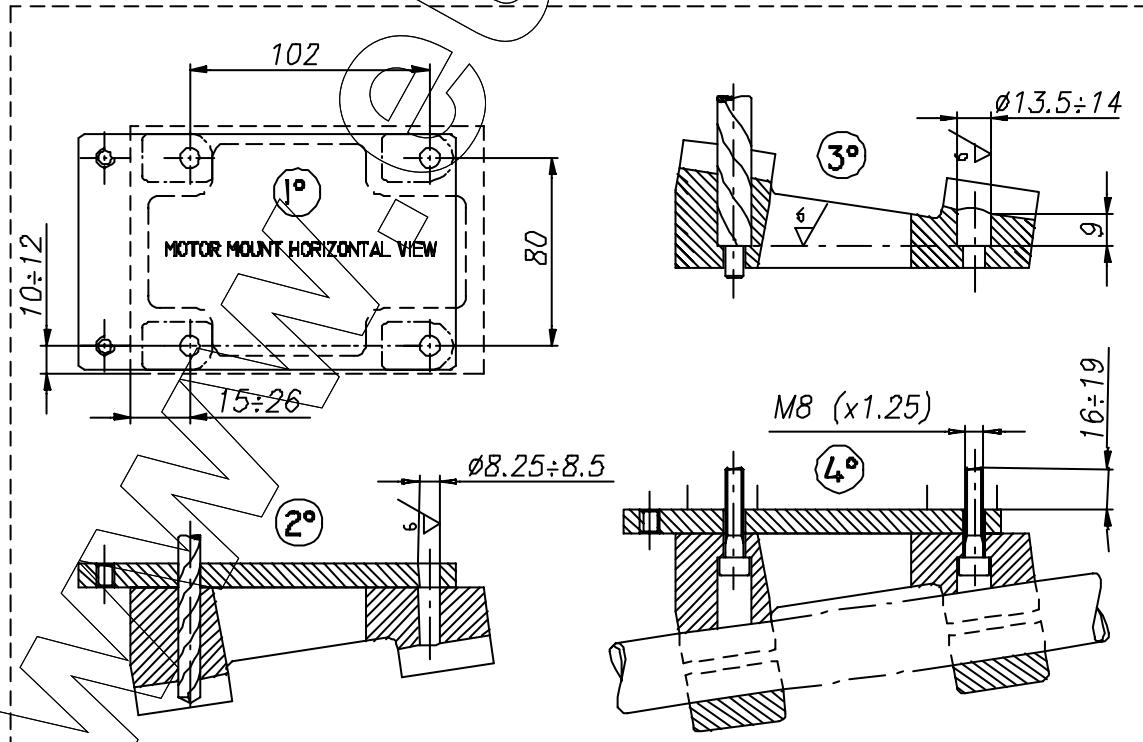
<p>3.2</p> <p>EXHAUST HEADER ASSEMBLY</p> <p>NOTE: THE ENGINE IS SUPPLIED WITH THE EXHAUST GASKET AND NUTS ALREADY INSERTED. WHEN THE SHIPMENT IS MADE AN EXHAUST COVER TO PROTECT THE INTERNAL PARTS.</p>	
<p>3.2.1 REMOVE THE NUTS AND THE EXHAUST COVER.</p>	
<p>3.2.2 MAKE SURE THE EXHAUST GASKET IS SEATED AND INSTALL THE EXHAUST HEADER (SEE FIG 1).</p>	<p>Fig.1</p> 
<p>3.2.3 INSTALL THE WASHERS</p> <p>SUGGESTION: PUT THE ENGINE IN HORIZONTAL POSITION AND SET INTO POSITION THE WASHERS WITH A SCREWDRIVER.</p>	
<p>3.2.4 INSTALL THE THREE NUTS. TORQUE AT 9 ÷ 11 Nm (80 ÷ 100 in-lb)</p>	<p>16 mm SOCKET WRENCH (OR 10 mm OPEN WRENCH.)</p>
<p>3.3</p> <p>PREPARATION AND INSTALLATION OF THE MOTOR MOUNT</p> <p>NOTE: ALL DIMENSIONS ARE IN MILLIMETERS</p>	
<p>3.3.1 DRILL 4 HOLES (DIAM. 8.5mm) IN THE MOTOR MOUNT.</p> 	

3.3.2 BEFORE INSTALLING THE MOTOR MOUNT, POSITION THE ADDITIONAL MOUNT PLATE ON THE CRANKCASE (SEE FIG. 2).



3.3.3 INSTALL THE MOTOR MOUNT. MAKE SURE TO USE M8 ALLEN SCREWS WITH A LENGTH SUCH AS TO ENGAGE, IN THE CRANKCASE, A THREADED PORTION LENGTH OF 16÷19mm (THE SCREW MUST PROTRUDE FROM THE PLATE FOR 16÷19mm) (SEE FIG. 3 AND DRAW. PAG. 9)

6 mm ALLEN WRENCH.

4 ALLEN SCREWS M8 – TORQUE AT 22÷24 Nm (190 ÷ 210 in-lb)



3.4 INSTALL THE CARBURETOR

3.4.1 INSTALL THE GAS CABLE CLAMP ON THE SUPPORT (SEE FIG. 4)

12 POINT WRENCH 10mm



3.4.2 REMOVE 2 SCREWS 3.5mm ON THE CARB. PUMP (IN CORRESPONDENCE OF THE THROTTLE LEVER) (SEE FIG. 5).

SCREWDRIVER 4.8 mm.

Fig.5

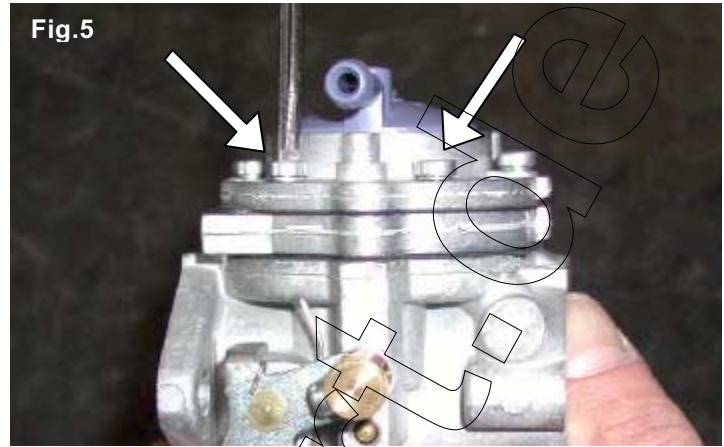

3.4.3 INSERT THE GAS BRACKET AND THE TWO SCREWS (SEE FIG. 6).

Fig.6



3.4.4 INSTALL THE INTAKE SUPPORT – 2 SCREWS M5 X10 (SEE FIG. 7)

3 mm ALLEN WRENCH

Fig.7



3.4.5 INSTALL THE CARBURETOR (SEE FIG. 8 / 9).

- REMOVE THE TWO M6 NUTS FROM THE INLET MANIFOLD.
- REMOVE THE PLASTIC PLUG FROM THE INLET MANIFOLD.



ATTENTION:
MAKE SURE THAT THE PRESSURE HOLE ON THE GASKET IS NOT PLUGGED.

10MM OPEN WRENCH

Fig.8

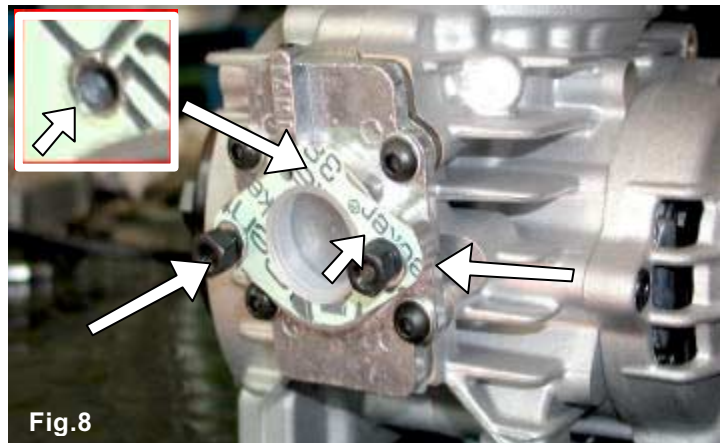



ATTENTION:
WHEN REPLACING THE CARB GASKET ALWAYS MAKE SURE THAT THE GASKET IS INSTALLED SO THAT THE HOLE IN THE GASKET MATCHES WITH THE TWO PRESSURE HOLES IN THE CARB. AND IN THE CRANKCASE. OTHERWISE THE ENGINE WON'T START.

INSTALL THE CARBURETOR.
N.2 NUTS M6 AND TWO WASHERS.
TORQUE AT 6 ± 10 Nm (50 ± 90 in-lb)



Fig.9

3.5 INSTALL THE ENGINE ON THE CHASSIS

3.5.1 POSITION THE ENGINE ON THE 2 OUTSIDE MAIN RAILS AND FIX THE MOTOR-MOUNT WITH THE TWO CLAMPS (SEE FIG.10)

SUGGESTION:
NEVER TORQUE COMPLETELY THE CLAMPS UNTIL THE CHAIN IS INSTALLED AND PROPERLY ALIGNED.



Fig.10

3.5.2 CHECK THE ALIGNMENT OF THE ENGINE SPROCKET AND THE AXLE SPROCKET WITH A STRAIGHT EDGE (SEE FIG. 11).

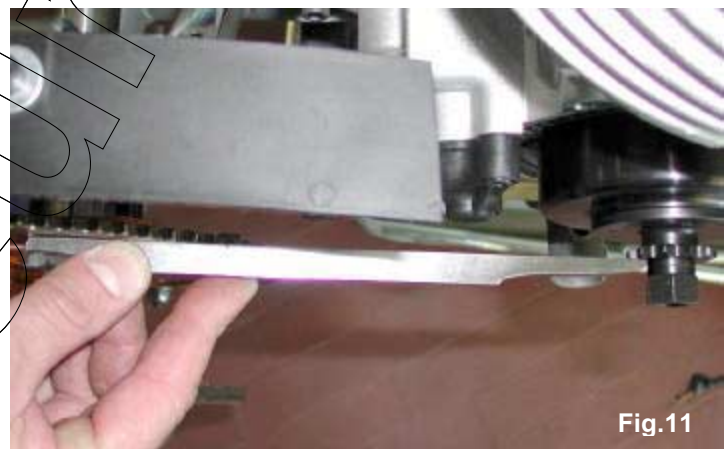

Fig.11

3.5.3 INSTALL THE CHAIN (PITCH: # 219) (SEE FIG. 12).



Fig.12

3.5.4 MOVE THE ENGINE ON THE RAILS AND OPTIMIZE THE CHAIN TENSION .



ATTENTION:
THE PLAY OF THE CHAIN MUST BE APPR. 15mm (½÷¾ inch) MEASURED IN THE SHOWN POINT (SEE FIG. 13)

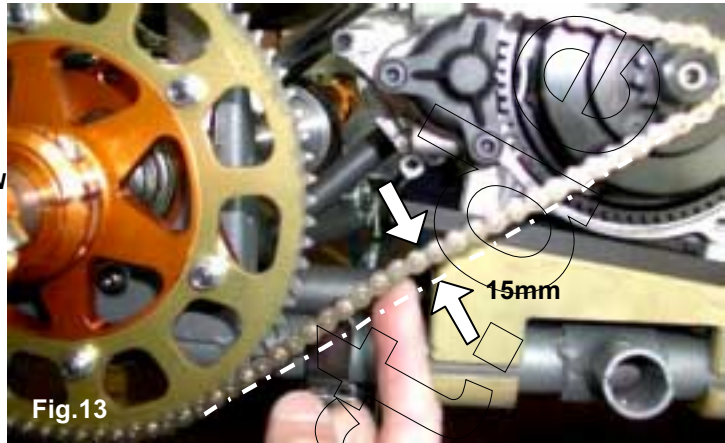

Fig. 13

3.5.5 TORQUE THE CLAMP SCREWS

3.6 INSTALL THE CLUTCH COVER WITH H.T. COIL

5mm ALLEN

3.6.1 REMOVE THE 3 SCREWS M6 X 30 ON THE CRANKCASE (SEE FIG. 14) AND INSTALL THE CLUTCH COVER WITH H.T. COIL (SEE FIG. 15).

TORQUE THE 3 SCREWS AT 8 ÷ 10 Nm (70 ÷ 90 in-lb)



ATTENTION:
ALWAYS MAKE SURE THAT THE GROUND CABLE ALWAYS CONNECTS THE COIL WITH THE ENGINE. AN INADEQUATE GROUNDING COULD DAMAGE THE IGNITION BEYOND REPAIR.

THE POSITION OF THE H.T. COIL HAS BEEN CHOSEN TO BE AS FAR AS POSSIBLE FROM THE EXHAUST AS THE EXCESSIVE HEAT COULD DAMAGE THE COIL BEYOND REPAIR.

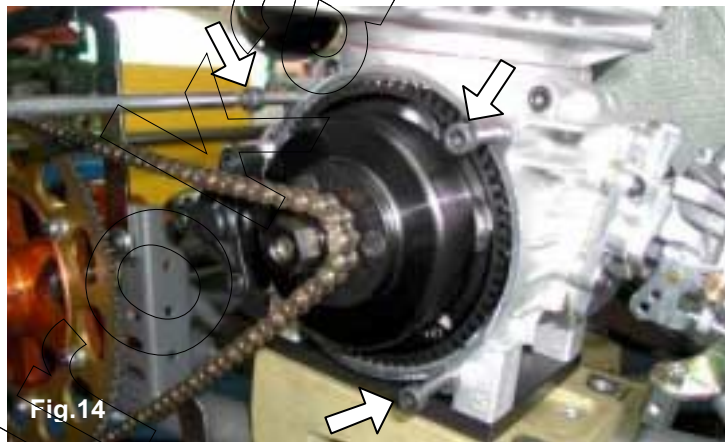

Fig. 14

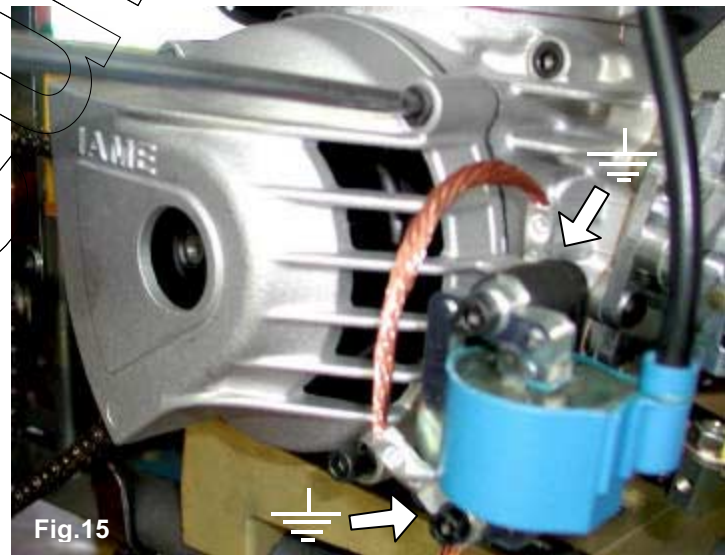

Fig. 15

ELECTRICAL CONNECTION
(refer to the attached electrical schematic)

3.7 INSTALLATION AND CONNECTION OF THE POWER PACK BOX.

NOTE:
THE POWER PACK BOX IS SUPPLIED ALREADY ASSEMBLED ON THE BATTERY SUPPORT (WITH BATTERY) . FOR A CORRECT INSTALLATION FOLLOW THE UNDER SHOWN INSTRUCTIONS.

3.7.1 EXTRACT THE BATTERY FROM THE SUPPORT AFTER HAVING UNLACED THE BATTERY STRAP (SEE FIG. 16).



3.7.2 POSITION THE SUPPORT CLAMPS ON THE OUTSIDE RAIL (BRAKE SIDE) AT THE HEIGHT OF THE SEAT.

NOTE:
DIFFERENT CLAMPS ARE AVAILABLE DEPENDING ON THE DIAMETER OF THE TUBE ON THE CHASSIS.

FIX THE CLAMPS **BY HAND** WITH 2 SCREWS M6 X 25 (SEE FIG. 17).

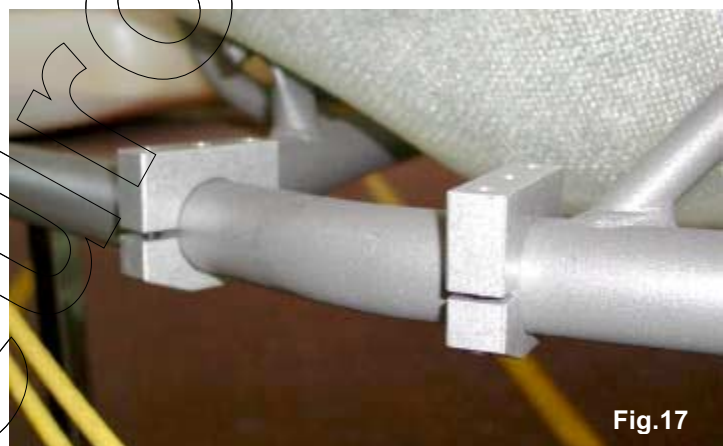

3.7.3 POSITION THE BATTERY SUPPORT BOX ON THE CLAMPS MATCHING THE ATTACHMENT HOLES (SEE FIG. 18). FIX THE BOX WITH TWO SCREWS M6 X 10. MOVE THE BOX WITH THE 2 CLAMPS TO THE MOST SUITABLE POSITION.

TORQUE THE M6 SCREWS AT 8 ÷ 10 Nm (70 ÷ 90 in-lb)

TWELVE POINT WRENCH 10mm

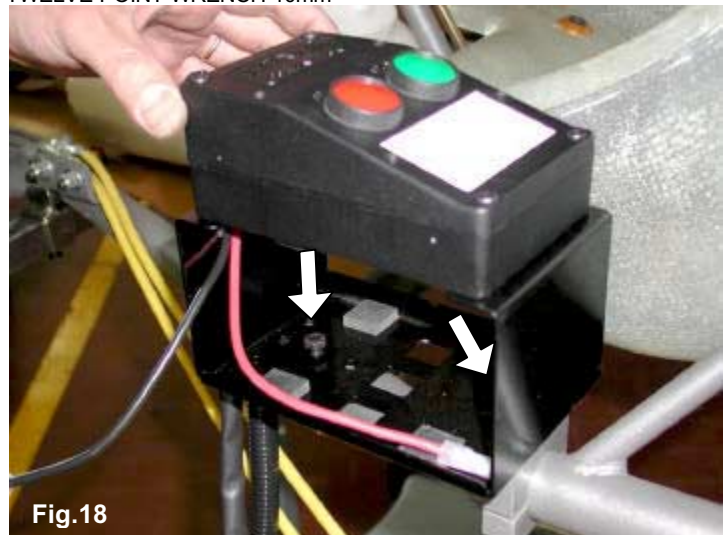

3.7.4 INSERT THE BATTERY STRAP (SEE FIG. 19).

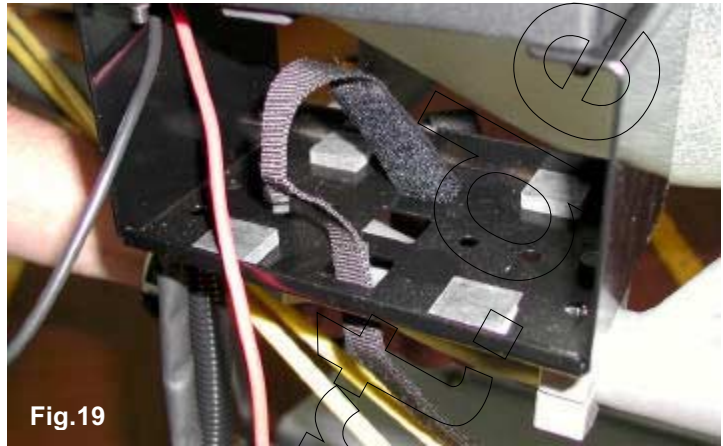

Fig.19

3.7.5 INSERT THE BATTERY WITH TERMINALS TOWARDS THE OUTSIDE (SEE FIG. 20).

SUGGESTION:
NEVER CONNECT THE BATTERY UNTIL YOU ARE READY TO START THE ENGINE. SEAL THE BATTERY TERMINALS WITH PLASTIC TAPE TO AVOID THAT EVENTUAL VIBRATIONS MIGHT DISCONNECT THE TERMINALS.



ATTENTION:
PAY ATTENTION NOT TO SHORT CIRCUIT THE BATTERY TERMINALS AS BATTERY COULD BE DAMAGED BEYOND REPAIR.



Fig.20

3.8 ELECTRICAL CONNECTIONS ON THE ENGINE

3.8.1 GROUND THE POWER PACK.



ATTENTION:
AN INADEQUATE GROUNDING OF THE POWER-PACK BOX COULD DAMAGE THE BOX BEYOND REPAIR. MAKE SURE TO CAREFULLY FOLLOW THE UNDER SHOWN INSTRUCTIONS.

3.8.2 POSITION THE HARNESS FROM THE POWER-PACK BOX ALONG THE CENTRAL RAIL, UNDERNEATH THE SEAT, AND TIGHTEN WITH PLASTIC CLAMPS (SEE FIG. 21).



ATTENTION:
NEVER LET THE HARNESS GET IN TOUCH WITH THE GROUND OR WITH ROTATING PARTS AS IT COULD BE DAMAGED BEYOND REPAIR.

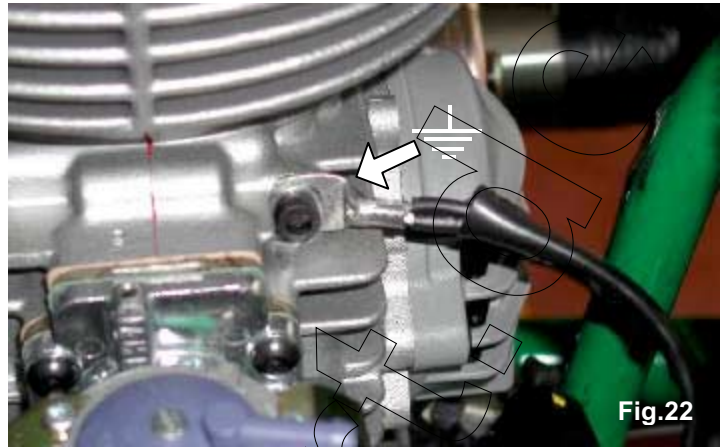

Fig.21

3.8.3 FIX THE GROUND CABLE, FROM THE POWER-PACK, ON THE ENGINE CARTER, BY MEANS OF THE PROPER THREADED HOLE (SEE FIG. 22).



ATTENTION:
THIS OPERATION IS EXTREMELY IMPORTANT AS AN UNCERTAIN GROUNDING COULD DAMAGE THE POWER PACK BOX BEYOND REPAIR.



3.8.4 CONNECT THE TERMINALS (3 AND 4 WAYS) ON THE HARNESS FROM THE POWER PACK BOX WITH THE TERMINALS ON THE CABLES FROM THE IGNITION (SEE FIG. 23-24).



ATTENTION:
MAKE SURE THAT THE FIXING TONGUES ARE PROPERLY INSERTED TO GUARANTEE THE BEST POSSIBLE CONNECTION OF THE TERMINALS.

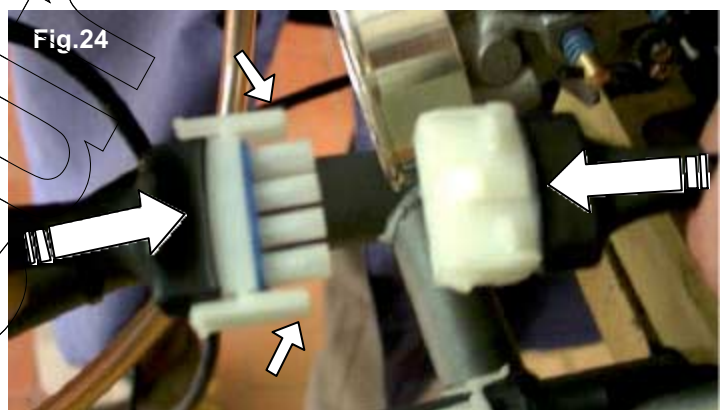
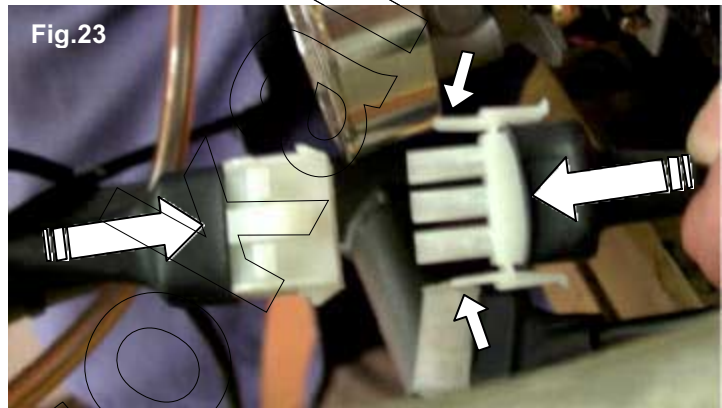

3.8.5 CONNECT THE CABLE TERMINAL (SINGLE), FROM THE POWER-PACK, WITH THE CABLE TERMINAL ALREADY CONNECTED TO THE STARTER (SEE FIG.25).



ATTENTION:
MAKE SURE THAT THE FIXING TONGUE IS PROPERLY INSERTED TO GUARANTEE THE BEST POSSIBLE CONNECTION OF THE TERMINALS.

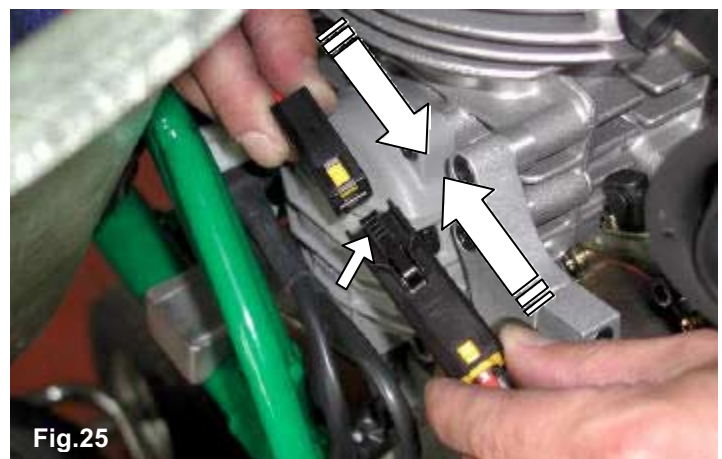

3.8.6 CHEK THE ELECTRIC STARTER CABLE FIXING (SEE FIG. 26) AND COMPLETE THE FIXING OF THE HARNESS (SEE FIG. 27).



ATTENTION:
NEVER LET THE HARNESS GET IN TOUCH WITH THE GROUND OR WITH A ROTATING PART AS IT COULD BE DAMAGED BEYOND REPAIR.

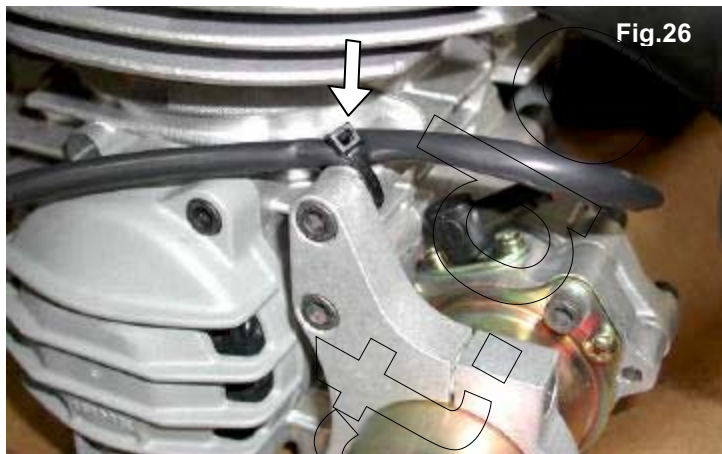

Fig.26



Fig.27

3.8.7 CONNECT THE COIL CABLE FROM THE POWER PACK TO THE TERMINAL ON THE COIL (SEE FIG. 28).

SUGGESTION:
SEAL THE TERMINAL ON THE COIL WITH PLASTIC TAPE TO AVOID THAT EVENTUAL VIBRATIONS MIGHT DISCONNECT THE TERMINAL.



Fig.28

3.8.8 PUNCTURE THE INSULATING MATERIAL ON THE H.T. CABLE WITH THE END OF THE CAP SPRING SO THAT THE SPRING IS IN SURE CONTACT WITH THE INTERNAL WIRE (SEE FIG. 29).

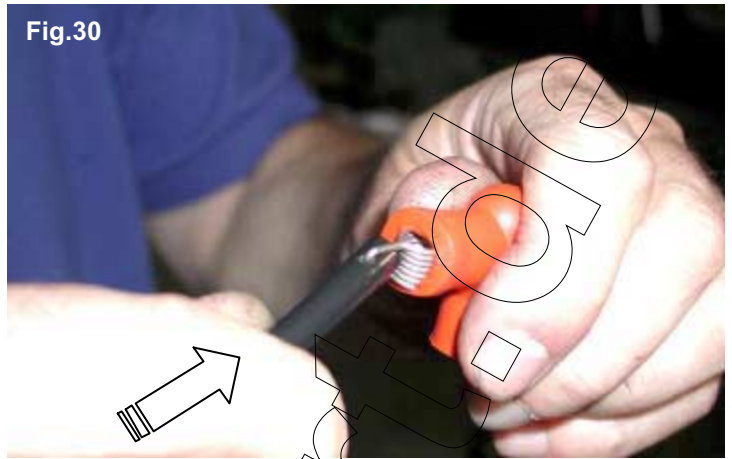

Fig.29

3.8.9 INSERT THE SPARK PLUG CAP ON THE SPRING (SEE FIG. 30). INSTALL THE SPARK PLUG AND THE CAP OVER THE SPARK PLUG.

- INSTALL THE SPARK PLUG
- INSTALL THE SPARK PLUG CAP MAKING SURE THAT THE SPRING IN THE CAP IS WELL INSERTED IN THE SPARK PLUG.

Fig.30



3.9 **INSTALL THE INTAKE SILENCER**



- MAKE SURE THAT THE FILTER HAS THE INLET HOLES TOWARDS THE UPPER SIDE.
- FIX THE FILTER ON THE CARB, WITH A STEEL CLAMP, AND THE FILTER TO THE CHASSIS SIDE RAILS WITH PLASTIC CLAMPS (SEE FIG. 31-32)

Fig.31



Fig.32

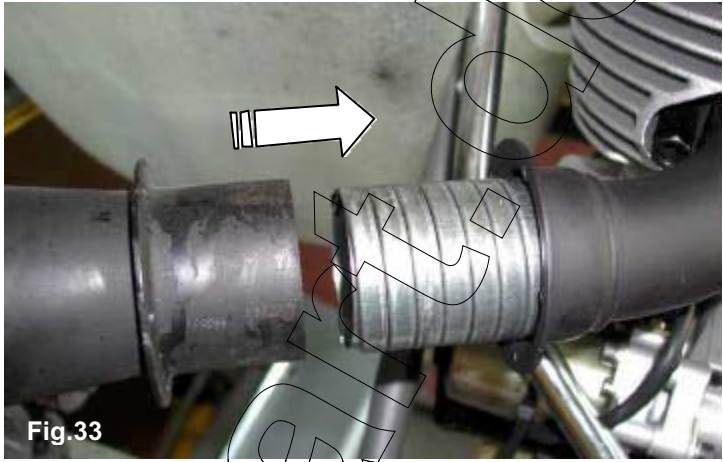

<p>3.10 INSTALL THE EXHAUST</p> <p>NOTE: SEE SECTION 9 FOR RECOMMENDATIONS ON THE IDEAL LENGHT OF THE EXHAUST.</p>	 <p>Fig.33</p>
<p>3.10.1 INSTALL THE FLEXIBLE (L= 65mm – FLEXIBLE COMPLETELY CLOSED) AND THE EXHAUST HEADER (SEE FIG. 33) AND CONNECT THE EXHAUST.</p>	 <p>Fig.34</p>

THE ENGINE IS READY TO BE STARTED

4- GASOLINE and OIL

Use leaded or unleaded Premium Gasoline (92 $\frac{\text{RON+MON}}{2}$) mixed with oil at 6% - (16:1).

Use oils containing Castor Oil which guarantees an optimized lubrication at high temperatures.

As on the other hand, use of Castor Oils creates gummy residues which give origin to carbon deposits, it is necessary to check and clean, at least every 5 ÷ 10 hours, the piston and the head.

Our experience dictates use of oils such as:

- Shell Advance Racing M
- ELF HTX 909
- ERG K KART 2T CORSE
- ERG K KART FORMULA

Once the fuel tank is filled, make sure that gasoline reaches the carburetor before starting the engine.

Never use the electric starter to suck the gasoline as this would discharge the battery.

SUGGESTION:

Disconnect the plastic tube on the carb. and the vent tube on the tank and pressurize the vent tube, until gasoline comes out from the tube on the carb. Make sure there is no air in the tube.

Connect the tube on the carb. and on the vent.

5- CARBURETOR ADJUSTMENT GUIDE

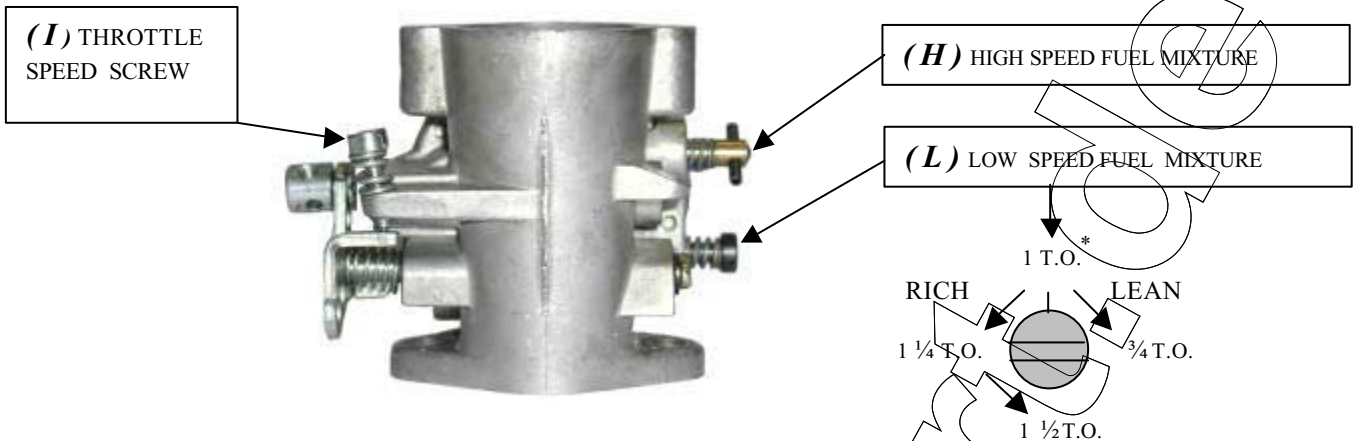

* T.O. = TURNS OPEN

Normally the correct setting of the mixture screws is the following:

- L (close the screw completely and then open): $1 \frac{1}{4} \div 1 \frac{1}{2}$ T.O.
- H (close the screw completely and then open): $1 \div 1 \frac{1}{4}$ T.O.

Based on various factors as altitude, ambient temperature etc. it might be necessary to reset the carburetor to optimize the performance of the engine.



ATTENTION:

- **Never lean too much as lean mixture will overheat engine and cause seizure**
- **Do not force H or L closed. It may damage the precision machined orifice and render the carb unserviceable.**
- **The adjustment of screw must be performed with warm engine.**

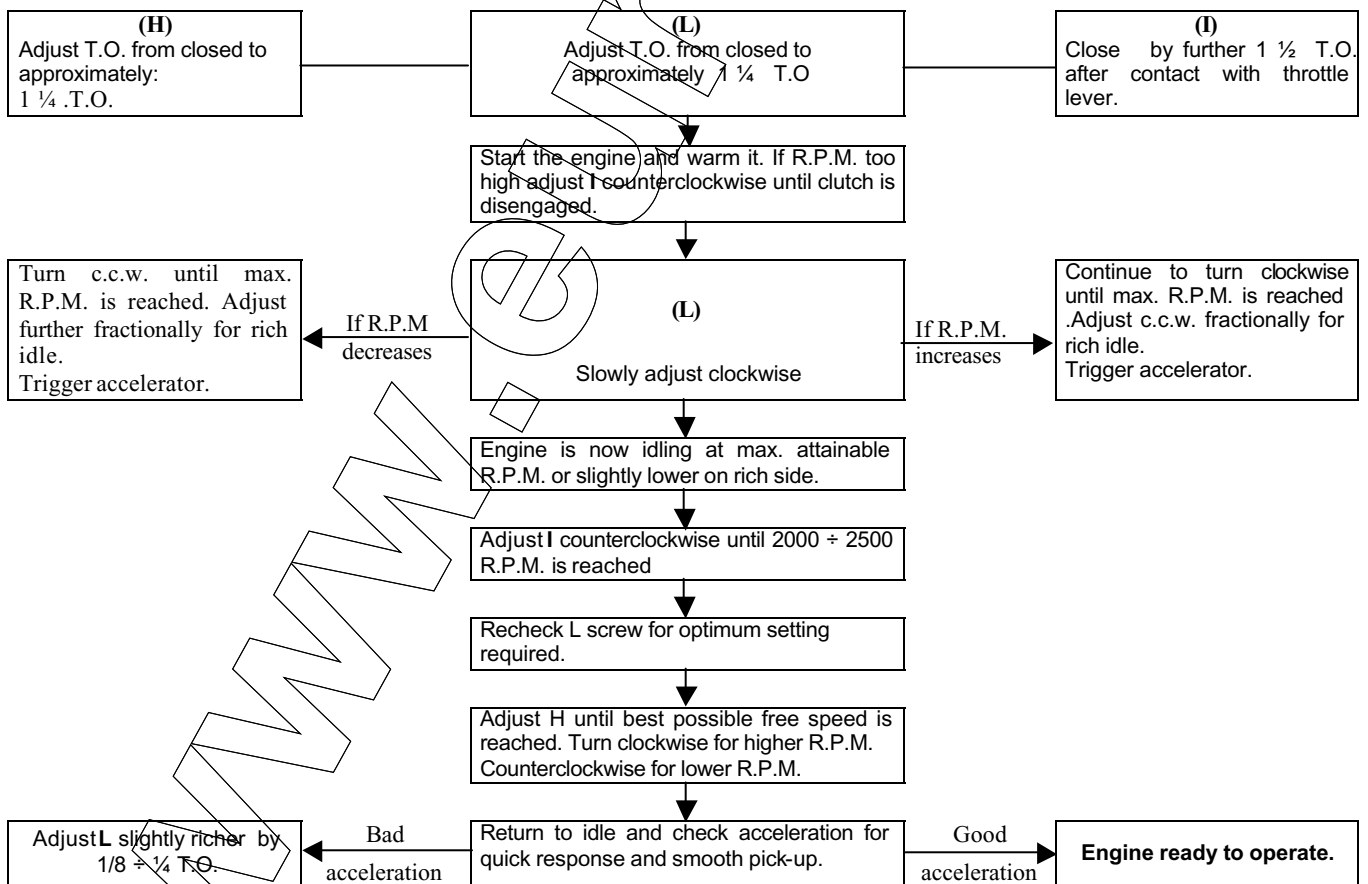

6- STARTING AND STOPPING THE ENGINE

Press the green button on the Power Pack .

If the engine can't be started within 5 seconds (check that gas gets to the carb.) interrupt and try again after 15 seconds. Shorts and frequent tries are better than long ones.

In case the engine can't be started refer to Par. 16 "Troubleshooting"

The engine can be stopped by pressing the red button on the Power Pack Box. Keep the button pressed until the engine has got to a complete stop.



ATTENTION:

In case of rain it is necessary to protect the Power Pack Box with the water proof plastic cover, as otherwise water by entering the box, could damage the circuits beyond repair.

When weather is good, remove the cover as the eventual condensation might damage the electrical circuits.

7- ENGINE BREAK-IN

The break-in of the engine must be performed following a few fundamental rules:

1. Adjust the carburetion. Start with an adjustment on the rich side.
2. Warm the engine gradually for about 5 minutes at half throttle, making some laps at low speed, gently closing and opening the carb. throttle (if a tachometer is installed never exceed 11.000 ÷ 12.000 RPM). **Never keep the same RPM for a long time.**
3. Progressively increase the speed of the kart for 5 minutes at $\frac{3}{4}$ throttle opening. **Never keep the same RPM for a long time.**
4. Increase the speed for 5 minutes, at max. speed on the twisty parts of the circuit and making the engine rich at half straight (cover with the hand for an instant the holes on the air filter, keeping the throttle wide open).



ATTENTION:

Once the break-in is over and the engine is cold, check the torque of the exhaust header nuts as, during the break-in, the nuts tend to become loose (refer to the attached table).

8- INLET SILENCER

Make sure that the inlet holes on the filter are towards the front of the kart and that they are not plugged.

Make sure that the clamp on the carburetor is not loosen and that the filter is well fastened to the chassis.

Once a while, clean the inside from oil deposits. If necessary remove the rubber filter union and clean it with gasoline or solvent.

9- EXHAUST SYSTEM

Before every test, make sure that the flexible is not damaged. Replace if necessary.



ATTENTION:

In case the flexible is damaged, metallic particles could be sucked in the engine and cause a seizure.

Always make sure that the springs are well hooked and in place. In case of breakage, replace the broken spring. **Never race the kart without the 3 springs in place**, as otherwise the exhaust pipe could vibrate beyond control.

Every 10 ÷ 15 hours, open the pipe end and make sure that the holes on the internal counter cone are not plugged.

The best performance is achieved with a total exhaust length of:

- $L = 410 \div 415$ mm.

Where L is measured from the flange on the exhaust header up to the first welding on the first cone of the exhaust muffler (see drawing).

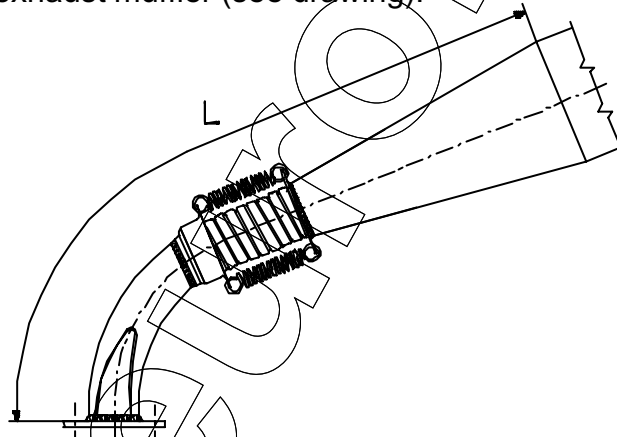

To achieve this dimension, the flexible (supplied with the engine) must be cut at a length of 65mm (flexible completely closed).

Having fixed a sprocket ratio, it could be necessary to improve the engine performance either at low or at high RPM.

This could be achieved by modifying the exhaust length.

In general, by shortening the total exhaust length an improvement at high RPM is achieved and vice versa, by lengthening the exhaust length the low RPM is improved.

When testing, never exceed in lengthening or shortening the flexible by more than 5mm per time.

10- CENTRIFUGAL CLUTCH

The engine has a low maintenance dry centrifugal clutch. The following prescriptions, if carefully followed, will allow a long clutch life.

When starting the engine make sure that the brake pedal is fully pressed to avoid sudden accelerations.



ATTENTION:

Once the engine is started, avoid useless accelerations which can overheat and deteriorate the clutch. Oil the chain before each tests, immediately after each race or test, check the engine sprocket. Replace if necessary.

A bad alignment of the engine sprocket with the axle sprocket or the lack of oil will damage the chain and sprocket.

Check the clutch:

- Every 5 hours of use.
- When metallic noises are heard inside the clutch.
- If the kart dragging speed exceeds 6000 RPM.
- Every time the clutch has overheated (presence of smoke or smell of burning).

To check the clutch, you must remove the clutch cover and the clutch drum.

Replace the clutch:

- whenever the thickness of the friction material (see drawing) is lower than 1.5mm on point A of the clutch or if the body diameter is lower than 82.5mm.
- whenever the external friction material in the A portion of the clutch is very rough (wear or degradation of the friction material due to overheating).



ATTENTION:

In case the friction material has been totally worn out and there has been a metal contact between the clutch body and the clutch drum, it is necessary to replace the clutch drum. See drawing.

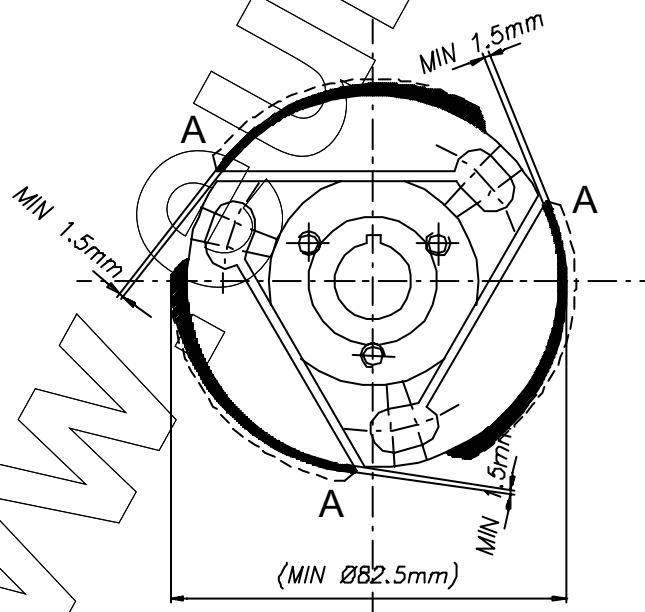

11- INSTRUCTIONS FOR THE DISASSEMBLY / ASSEMBLY OF THE CLUTCH





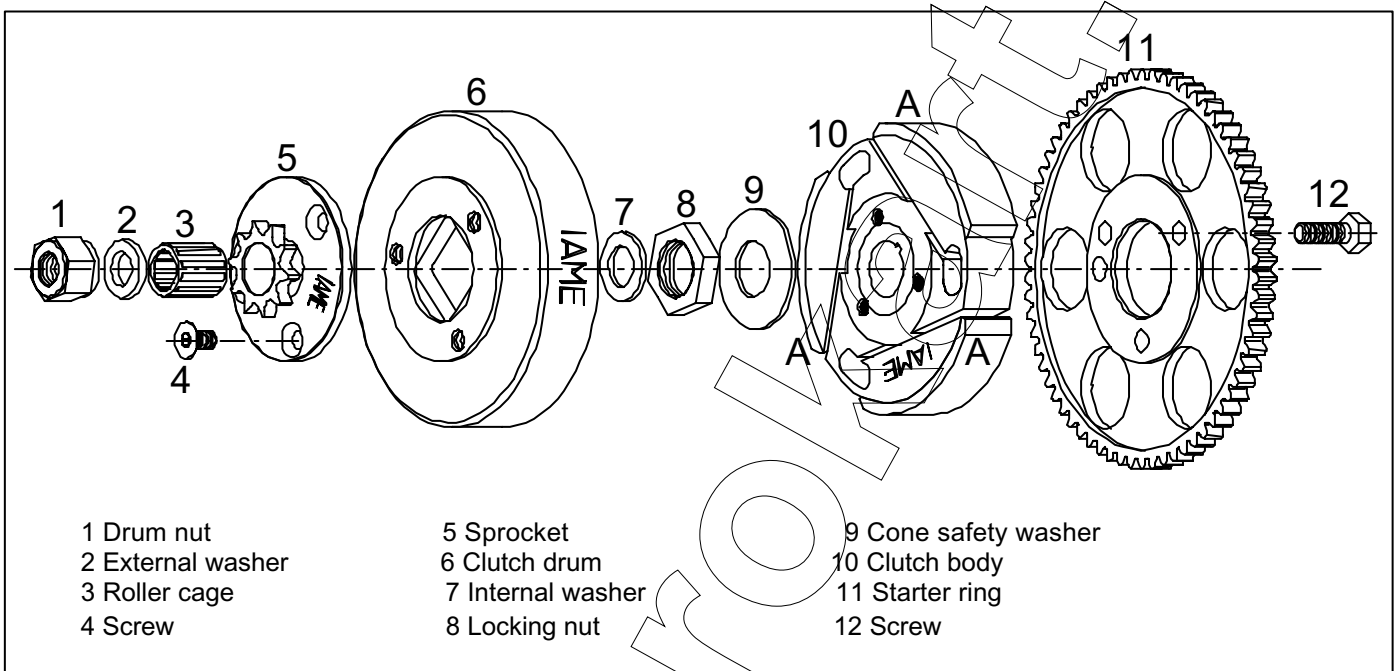

ATTENTION:

The following operations can be performed by a skilled mechanic under the conditions to have available the dedicated tools shown on the text, otherwise it is necessary to apply to an Authorized Service Center.
Refer to the following drawing during the operations.



<u>OPERATIONS</u>	<u>TOOLS</u>
Clutch disassembly	
1. Remove the clutch cover (3 screws M6).	▪ Allen wrench 5mm – T type
2. Remove the spark plug and replace with special tool to prevent crankshaft from turning.	▪ Piston fitting : P.N. 10271
3. Remove nut (1 nut M10).	▪ 12 Point wrench - 17 mm
4. Remove the external washer, the drum with roller bearing, the internal washer.	
5. Remove the special tool from the head and using the clutch wrench, remove the 16x1 nut and the cone safety washer.	▪ Clutch wrench : P.N. 10270 ▪ 24 mm socket.
ATTENTION: <u>Turn clockwise as nut has left thread.</u>	
6. Apply clutch puller on clutch and remove clutch with 19mm socket.	▪ Clutch puller: P.N. B-55614-C ▪ 19mm socket.
7. Remove key from shaft.	
8. Remove the starter ring (3 screws M6)	▪ 10 mm socket

Before assembling the clutch, wash with diluent the shaft taper, the connecting hole on the clutch body, the clutch drum and the starter ring.

Clutch assembly	
<p>1. Install the starter ring on the clutch body by matching the 3 holes and the dragging pin. (3 screws M6)</p> <p> ATTENTION: make sure to always install the \varnothing 7 mm dragging pin as, otherwise, the eventual kick backs could break the screws.</p>	<ul style="list-style-type: none"> ▪ 10 mm socket (Torque at 10 Nm) (90 in-lb) (Apply Loctite on the threads)
2. Insert key on shaft.	
3. Install clutch body and the cone safety washer.	
<p>4. Install the 16 x 1 nut using the clutch wrench.</p> <p> ATTENTION: turn counterclockwise as nut has left thread.</p>	<ul style="list-style-type: none"> ▪ Clutch wrench P.N. 10270 ▪ 24 mm. socket (Torque at 40 ÷ 50 Nm) (350 ÷ 440 in-lb)
<p>5. Install the internal washer.</p> <p> ATTENTION: install washer with bevel towards internal part of engine. clean the roller cage and grease it before installing it on the crankshaft.</p>	
<p>6. Install the clutch drum and the external washer.</p> <p> ATTENTION: install washer with bevel towards internal part of engine.</p>	
<p>7. Install the piston fitting to prevent the shaft from turning and install the 10 mm nut.</p>	<ul style="list-style-type: none"> ▪ Piston fitting : P.N. 10271 ▪ 17 mm socket (Torque at 30 ÷ 40 Nm) (265 ÷ 350 in-lb)
8. Install the clutch cover (3 screws M 6)	<ul style="list-style-type: none"> ▪ Allen 5 mm. (Torque at 8 ÷ 10 Nm) (70 ÷ 90 in-lb)

12- BATTERY

The battery (12 V – 7.2 Ah) is sealed and without maintenance.

In order to lengthen the battery life it is necessary though to follow a few recommendations:

- When the tension drops below 12.6V it is necessary to recharge the battery.
- Max. allowed recharging current is 1.8A.
- The ideal recharge is achieved with an average charging current of 0.8 ÷ 1 A. (recharging time of appr. 10 h.) and at an ambient temperature between 0° and 40°C.



ATTENTION:

An overcharge or an extremely quick charge with excessive current could damage the battery (the battery would tend to swell).

Choose a battery charger with the following characteristics:

- Feed Tension: 90/250 Vac – 50/60 Hz
- Outlet Tension: 15 V full charge – 13.8 stand-by
- Max outlet current: 2A full charge
- During transportation or storage, the battery could loose its charge due to self discharge (0.1% max per day).

Fully recharge battery before use.



ATTENTION:

Always connect the - (negative) terminal before and the + (positive) terminal after. Always disconnect the battery in opposite order.

- Recharge the battery at least once every 6 months.
- Never put the battery in contact with solvents, gasolines, oils, plastifiers or rags containing such elements. The external case of the battery could be damaged.
- Never press or bend or overheat (by welding) the battery terminals.

Other recommendations

- Pay attention not to have free fires upon or around the battery.
- Never shortcircuit the terminals.
- Never open the battery or throw it in the fire.
- In case the electrolyte (diluted Sulfuric acid) gets in contact with skin or clothes, immediately wash with water. In case it gets in touch with eyes, wash and apply for medical assistance.
- Carefully check the external case of battery and replace in case of breakages, swellings of the case or of battery cover.
- Before use, clean the battery from dust and check that the terminals are not oxidized or damaged.
- When the battery comes to an end never throw it in the garbage but deliver it to an authorized disposer.

13- SPARKPLUG AND THERMAL DEGREE

The engine is supplied with a standard **NGK BR10EG** sparkplug which represents a good compromise between the needs of a good break-in and the racing needs in normal conditions.

Use of different sparkplugs is possible and, as a general information, we are attaching a correspondence list among sparkplugs of other brands based on **thermal degree** which represents the capacity of the sparkplug to dissipate the internal heat. The colour of the various parts of the sparkplug more exposed to the combustion flames gives a good indication on the adequacy of the thermal degree and on the carburetion. It is necessary though to understand which of the two parameters has to be changed and only the experience tells how to identify the most proper thermal degree of a sparkplug as lean or rich mixtures can generate the same final look which can also be achieved with a hot or cold sparkplug.

See table:

<p>An excessively warm sparkplug shows the symptoms listed aside</p>  <p>ATTENTION: <u>Always use a warmer than standard spark plug with cold or rainy climates.</u></p>	<ul style="list-style-type: none"> ▪ Extremely clear color, porous look and calcification of the electrodes and of the internal insulation. ▪ Irregularities in the ignition, preignition and detonation with tendency to perforate the top of the piston. ▪ Note: Some of these symptoms can be achieved with lean mixtures.
<p>A correct thermal degree shows:</p>	<ul style="list-style-type: none"> ▪ Colour of the insulator end from yellow grey to dark brown for mixtures respectively lean or rich.

An excessively cold sparkplug shows the symptoms, listed aside.



ATTENTION:
Always use a colder than standard sparkplug with hot climates.

- Insulator end and electrodes covered with black shiny soot.
- Ignition difficulties.
- **Note:** a wet or oily electrode could also mean an excessively rich mixture.

COMPARISON TABLE BASED ON THE THERMAL DEGREE

HOT



BOSCH	NGK	CHAMPION
WO8CS	BR9EG	N54R
WO7CS	BR10EG	N52R
WO6CS	BR11EG	



COLD

14- CHOICE OF THE BEST SPROCKET RATIO

The life of an engine depends upon many factors but most of all upon the speed at which the engine is operated. If an engine is normally operated at speeds higher than what recommended by the manufacturer, the wears and stress of the various components (con-rods, roller cages, bearings etc.) will be such as to drastically reduce the life of the engine itself. It is therefore extremely important that the user respects the operating limits imposed by the manufacturer.

The operating limit for the Leopard engine is 15000 RPM.



ATTENTION:
Never exceed the above limit. No obligation of IAME exists in case the above limit is exceeded.

In case the user wishes to optimize on the track the sprocket ratio in order to achieve the best possible performance, without abusing the engine, follow the under shown recommendations.

The engines are supplied with a 10 or 11 teeth sprocket (pitch: # 219). Table 1 shows the various ratios between the sprocket on the axle and the engine sprocket given the different axle sprockets.

Tab.1

Sprocket ratio	Teeth n° - Engine sprocket		Sprocket ratio	Teeth n° - Engine sprocket	
	Teeth n° - axle sprocket	10		11	Teeth n° - axle sprocket
72	7,20	6,55	83	8,30	7,55
73	7,30	6,64	84	8,40	7,64
74	7,40	6,73	85	8,50	7,73
75	7,50	6,82	86	8,60	7,82
76	7,60	6,91	87	8,70	7,91
77	7,70	7,00	88	8,80	8,00
78	7,80	7,09	89	8,90	8,09
79	7,90	7,18	90	9,00	8,18
80	8,00	7,27	91	9,10	8,27
81	8,10	7,36	92	9,20	8,36
82	8,20	7,45			

For the operation limit of 15000 RPM the following table (Tab.2) has been prepared.

SUGGESTION:

- During the track tests we recommend use of a tachometer recording the max obtained engine RPM.
- Use sparkplug caps with a resistance of 5KΩ to avoid eventual interferences between the engine ignition and the tachometer and/or telemetry.

The following example should clarify the procedure for the optimization of the sprocket .

Assume to use the engine with Z=10 teeth engine sprocket and that during the preliminary track tests a Z=72 teeth axle sprocket has been used.

- From table 1 with Z=10 as engine sprocket and Z=72 on the axle sprocket, a ratio of 7.20 is found.
- Make a few laps on the track and, let us assume that you read 14.000 max engine RPM.
- From the table 2 to achieve a max RPM of 15000 RPM (operating limit for the Leopard engine) a sprocket ratio from 7.61 and 7.82 should be used (having used, during the tests, a sprocket ratio of 7.2 and having achieved 14.000 RPM max.).
- From table.1 , with these values, a sprocket ratio of 10:76 / 10:78 should be used or, having a Z=11 on the engine sprocket, a ratio 11:85 should be used.

Sprocket ratio to achieve max 15000 RPM

Tab. 2

Engine max RPM during tests	Sprocket ratio														
	6,5	6,7	6,9	7,1	7,3	7,5	7,7	7,9	8,1	8,3	8,5	8,7	8,9	9,1	9,3
13000	7,50	7,73	7,96	8,19	8,42	8,65	8,88	9,12	9,35	9,58	9,81	10,04	10,27	10,50	10,73
13200	7,39	7,61	7,84	8,07	8,30	8,52	8,75	8,98	9,20	9,43	9,66	9,89	10,11	10,34	10,57
13400	7,28	7,50	7,72	7,95	8,17	8,40	8,62	8,84	9,07	9,29	9,51	9,74	9,96	10,19	10,41
13600	7,17	7,39	7,61	7,83	8,05	8,27	8,49	8,71	8,93	9,15	9,38	9,60	9,82	10,04	10,26
13800	7,07	7,28	7,50	7,72	7,93	8,15	8,37	8,59	8,80	9,02	9,24	9,46	9,67	9,89	10,11
14000	6,96	7,18	7,39	7,61	7,82	8,04	8,25	8,46	8,68	8,89	9,11	9,32	9,54	9,75	9,96
14200	6,87	7,08	7,29	7,50	7,71	7,92	8,13	8,35	8,56	8,77	8,98	9,19	9,40	9,61	9,82
14400	6,77	6,98	7,19	7,40	7,60	7,81	8,02	8,23	8,44	8,65	8,85	9,06	9,27	9,48	9,69
14600	6,68	6,88	7,09	7,29	7,50	7,71	7,91	8,12	8,32	8,53	8,73	8,94	9,14	9,35	9,55
14800	6,59	6,79	6,99	7,20	7,40	7,60	7,80	8,01	8,21	8,41	8,61	8,82	9,02	9,22	9,43
15000	6,50	6,70	6,90	7,10	7,30	7,50	7,70	7,90	8,10	8,30	8,50	8,70	8,90	9,10	9,30
15200	6,41	6,61	6,81	7,01	7,20	7,40	7,60	7,80	7,99	8,19	8,39	8,59	8,78	8,98	9,18
15400	6,33	6,53	6,72	6,92	7,11	7,31	7,50	7,69	7,89	8,08	8,28	8,47	8,67	8,86	9,06
15600	6,25	6,44	6,63	6,83	7,02	7,21	7,40	7,60	7,79	7,98	8,17	8,37	8,56	8,75	8,94
15800	6,17	6,36	6,55	6,74	6,93	7,12	7,31	7,50	7,69	7,88	8,07	8,26	8,45	8,64	8,83
16000	6,09	6,28	6,47	6,66	6,84	7,03	7,22	7,41	7,59	7,78	7,97	8,16	8,34	8,53	8,72
16200	6,02	6,20	6,39	6,57	6,76	6,94	7,13	7,31	7,50	7,69	7,87	8,06	8,24	8,43	8,61
16400	5,95	6,13	6,31	6,49	6,68	6,86	7,04	7,23	7,41	7,59	7,77	7,96	8,14	8,32	8,51
16600	5,87	6,05	6,23	6,42	6,60	6,78	6,96	7,14	7,32	7,50	7,68	7,86	8,04	8,22	8,40
16800	5,80	5,98	6,16	6,34	6,52	6,70	6,88	7,05	7,23	7,41	7,59	7,77	7,95	8,13	8,30
17000	5,74	5,91	6,09	6,26	6,44	6,62	6,79	6,97	7,15	7,32	7,50	7,68	7,85	8,03	8,21

15- SCHEDULED MAINTENANCE

Following some simple maintenance standards will allow the engine to perform more reliably and have a longer life.

SCHEDULE	COMPONENTS	ACTIONS AND COMMENTS
Before using	Exhaust flexible	Check status
	Exhaust springs	Check status
	Exhaust strap	Check status
	Exhaust muffler	Check status and fixing
	Engine sprocket	Check wear Check alignment with axle sprocket
	Engine chain	Check status, tensioning, and oil chain
	Battery	Check status and charge
	Cables and connectors	Check status and connections
	Grounding of engine and Power Pack	Check status and connections
	Engine mount and clamps	Check torques
After use	Battery	Disconnect
	Chain	Check status and oil chain
	Engine	External cleaning
Every 5 - 10 hours	Bendix assembly	Remove cover (see fig.) and clean internally
		
	Exhaust muffler	Remove muffler end, clean
	Inlet silencer	Open, clean
	Engine head	Open, clean
	Engine clutch	Open, check status of parts
	every 20 hours	Piston and Con-rod assembly
Crankshaft		Check and replace worn parts
Ball bearings		Check and replace worn parts

16- TROUBLESHOOTING

Below are some common faults, their probable causes and suggested remedy:

FAULTS	PROBABLE CAUSE	REMEDY
Starter will not crank when pushing the start button.	Bad connections on starter cables.	Check and tighten
	Bad grounding	Check connections and tighten
	Damaged cables	Replace
	Battery connection loose	Check and tighten
	Battery discharged	Recharge battery
	Starter failure	Overhaul starter
Starter cranks but engine won't start	Power Pack internal failure (fuse starter relay, connectors)	Apply to Authorized Service Center
	Bad cable connections	Check connectors (3 and 4 ways)
	Bad H.T. coil connection or coil failure	Check/Replace
	Bad H.T. coil grounding	Check and tighten (2 grounds)
	Power pack internal cable bad connection	Apply to Authorized Service center
	Wet spark plug	Replace
Engine starts when the start bottom is pressed but it stops when bottom is released.	Malfunction on induction system	Check status and connections on fuel pipe Replace gaskets and membranes on carburetor Check reed petals. Replace if necessary.
	Bad cable connections	Check stator connector (4 ways).
	Bad connections on Power-Pack internal cables	Apply to Authorized Service Center
The starter cranks after having released the start button	Bad carburetor adjustment (I screw)	Check carburetor adjustment (see par. 5)
	Battery discharged (starter relay does not disconnect).	Disconnect the positive terminal on battery and charge battery.
Rough idle	Bad carburetor adjustment (L Screw)	Check carburetor adjustment (see par. 5)
Drop in engine performance	Bad compression	Check piston
	Bad carburetor adjustment	Check carburetor adjustment (see par. 5)
	Insufficient gas flow	Check gasoline flow lines
	Dirty inlet silencer	Check and clean
Burning smell, smoke	Overheating of clutch	Check clutch (Par. 11)
Clutch engages at too high RPMs	Excessive wear of friction material	Check clutch (Par. 11)
Exhaust too noisy	Flexible damaged	Check and replace if necessary
	Springs damaged or lost	
	Insulating strap damaged or lost.	
	Damaged exhaust header	

17- ENGINE PRESERVATION

When engine is to remain unoperative for a long period it must be preserved as follows:

- Disconnect the battery and charge it periodically (see Par. 12)
- Disconnect carburetor and clean it
- Seal with tape the engine inlet and exhaust

The external of the engine must be cleaned. Spray with protective oil the steel parts subject to oxidation.

Keep the engine in a dry ambient.

www.eurokart.it

FASTENER TORQUE VALUES ("LEOPARD" ENGINE)

NOMINAL SIZE	Q.TY	FASTENER NAME	WRENCH	VALUES(Nm)	VALUES(in•lb)
M14 x 1.25	1	Spark plug	Hex.20.8	20 - 26	175 - 230
M8 x 1.25	4	Head and cylinder nut	Hex. 13	18 - 22	160 - 190
M6 x 1	3	Exhaust nut	Hex. 10	9 - 11	80 - 100
M6 x 1	4	Reed group screw	Allen 5	8 - 10	70 - 90
M6 x 1	2	Carburetor attach. nut	Hex. 10	6 - 10	50 - 90
M5 x 0.8	2	Air filter screw	Allen 4	5 - 6	45 - 50
M5 x 0.8	2	Coil attach. screw	Allen 4	5 - 6	45 - 50
M6 x 1	3	Ignition cover screw	Allen 5	8 - 10	70 - 90
M5 x 0.8	4	Ignition stator fixing screw	Allen 4	5 - 6	45 - 50
M8 x 1.25	1	Ignition rotor fixing nut	Hex. 13	18 - 22	160 - 190
M6 x 1	4	Starter support fixing screw	Allen 5	8 - 10	70 - 90
M6 x 1	3	"Bendix" support fixing screw	Allen 5	6 - 8	50 - 70
M6 x 1	3	Starter attach. screw	Allen 5	8 - 10	70 - 90
M6 x 1	3	Clutch cover attach. screw	Allen 5	8 - 10	70 - 90
M10 x 1	1	Clutch drum holding nut	Hex. 17	30 - 40	265 - 350
M16 x 1	1	Clutch fixing nut	Hex. 24	40 - 50	350 - 440
M5 x 0.8	3	Engine sprocket fixing screw	Allen 3	6 - 8	50 - 70
M6 x 1	3	Starter ring fixing screw	Hex. 10	9 - 11	80 - 100
M6 x 1	7	Crankcase fixing screw	Allen 5	8 - 10	70 - 90
M6 x 1	3	Add. starter supp. fix. screw	Allen 5	8 - 10	70 - 90
M6 x 1	1	Additional supp. locking screw	Allen 5	8 - 10	70 - 90

MAN

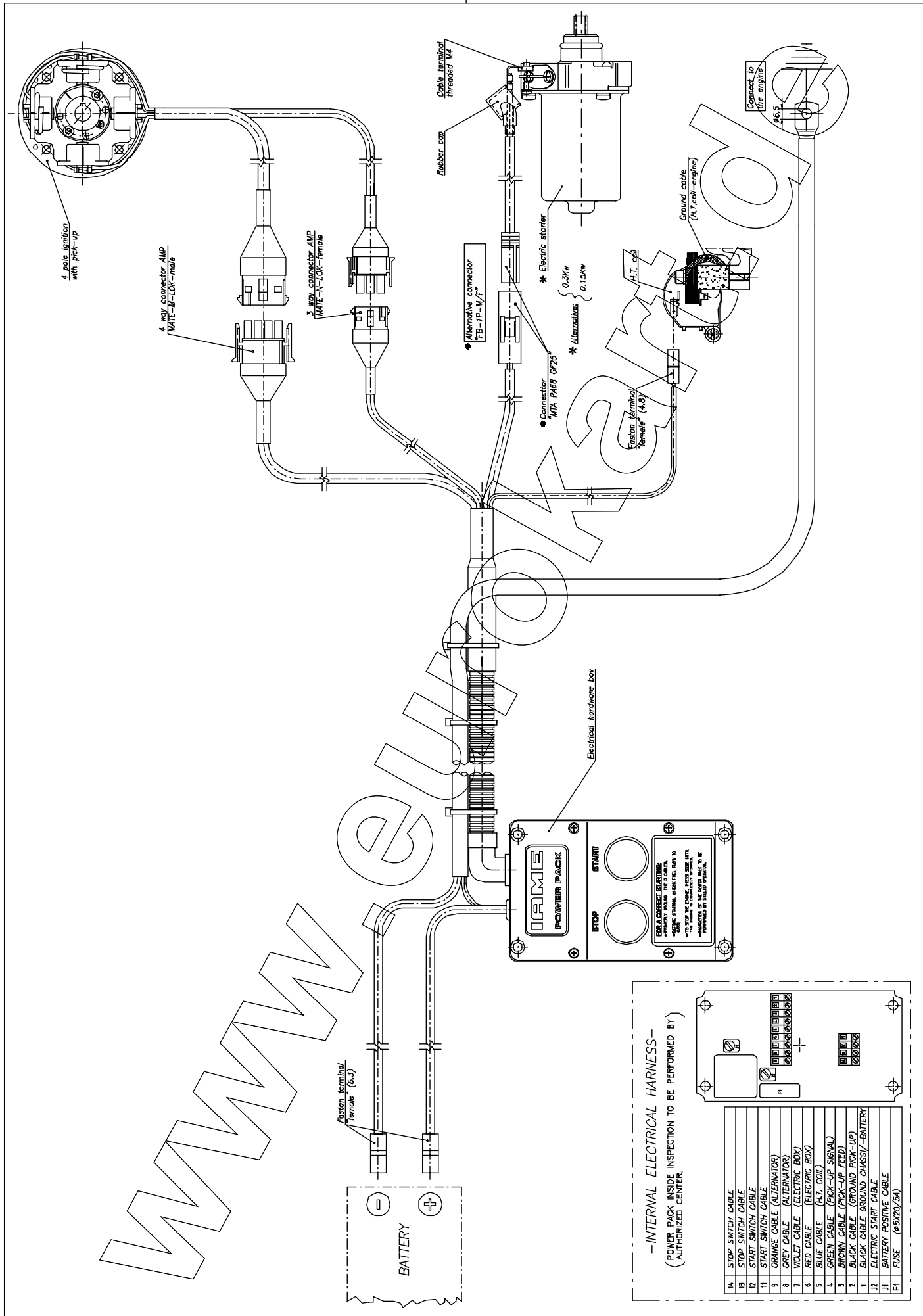

www.eurokaf.com

WIRING DIAGRAM

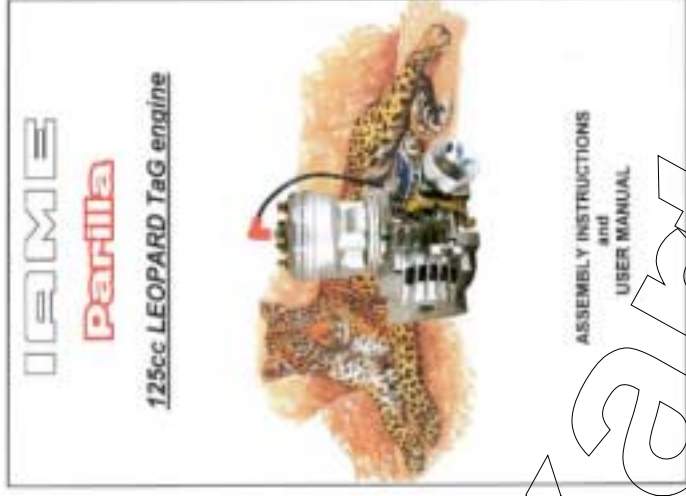

Assembly Instructions
& User Manual

© 2001 by IAME joint stock Comp.
1st Edition , November/2000
All rights reserved. Any reprinting or
Unauthorized use without the written
Permission of IAME joint stock Comp.
Is expressly prohibited